

Mk.IV (Example #1).



This is the forgotten photo that was found on an old hard disk drive (Example #1). Notice the handwritten letters at the top left, believed to indicate 'Mk.IV' and 'Serial 30'. The source and current location of this example are unknown.

Mk.IV (revision v 1.01)

Country of origin:
England

REMARKS

When recently checking the contents of an old hard disk drive before wiping and discarding it, a forgotten jpeg format photo of an agent's set was discovered, which appeared to be a Mk.VI variation 3, taken in 2006 (Example #1 left). Upon enlarging the image, some vague handwritten letters in the top left corner were noted, reading 'IV 30,' which might indicate Mk.IV with serial number 30. This serial number was also present on the receiver coil: '40M PC 30.' The lettering of these numbers was most likely done by hand, as was evident from the clarity of the handwriting on the receiver coil, as opposed to the engraved lettering of the controls

Remembering that at the time when WftW Volume 4 'Clandestine Radio' was produced, we were puzzled because no 'Mark' number matched a number of similarly looking sets. For that reason, we reluctantly assigned the provisional names 'Mk.VI variations 2 and 3'.

It might therefore be speculated that the Mk.VI provisional variation 3 could actually have been a Mk.IV, with Mk.VI variation 2 having just a different layout and a 6V DC power supply unit. This is a more likely designation as the Mk.VI was very different with a much more powerful transmitter and a more advantageous type receiver. (Refer to pages Mk.VI in WftW Volume 4 for further details). Pat Hawker, G3VA, wrote to me in 2001, '.. believed that the Mk.IV existed as an agent's set but no details are known ...' and '... that there were many 'specials' developed to meet particular requirements and Mark numbers allocated to prototypes which were later not produced...'

The receiver coil of a similar set (Volume 4, page Mk.VI-3, and Example #2 in this chapter) was marked '40 PC 8', which coincided with the letters 'PC 8' on the top left-hand side of the front panel. Ultimately, photographs of nine units currently found, of which eight had survived, are shown in this WftW Supplement. There is little doubt that more are in the hands of collectors and museums.

Developed early in WW2.

Information that came with photographs of two similar Mk.IV suitcase sets, already published in WftW Volume 4, (in this chapter Examples #2 and #4) indicated that these were dropped to agents in Norway early in WW2. A photograph retrieved from a German Ordnungspolizei handbook, 'Die Funkpeilung der kurzen Wellen', showed a Mk.IV (Example #5) that was captured from an agent in 1941. A 6V DC variation of the Mk.IV (Example #6), previously named Mk.VI variation 2, was dropped to a Milorg group in Norway in January 1942.

In this WftW Chapter, the currently known Mk.IV's that survived will be discussed, along with their variations, particularly variation 3 in example #9, which is believed to have led to the development of the Mk.VII, better known as Paraset. It is unfortunate that no firm confirmation of the assumptions could be sought in archives not accessible to the public.

DATA SUMMARY

- Organisation:** MI6 SIS.
- Design/Manufacturer:** SIS Section VIII, Whaddon Hall / Little Horwood workshops.
- Year of Introduction:** 1941, possibly earlier.
- Purpose:** Agents.
- Transmitter:**
 - Circuit features:** Crystal Oscillator. CW only.
 - Freq. Coverage:** 3.5-8MHz in two bands covered by plug-in coils: 3.5-7MHz (80M), 6.5-8MHz (40M).
 - RF output:** Estimated 4-6W.
 - Valve:** 6V6.
- Receiver:**
 - Circuit features:** TRF with regenerative detector, AF stage, AF output.
 - Freq. Coverage:** 2.3-8MHz covered by two plug-in coils: 2.3-5.2MHz (marked 80M) and 4.2-8MHz (marked 40M).
 - Valves:** 6SK7, 6C5 (2x).
In variation 3: 2x 6SK7.
- Power Supply:** Internal 100-245V, 50Hz, AC mains power unit; 6X5 rectifier.
In variations 2 and 3 separate power supply units for 6V DC and 100-245V, 50Hz, AC mains.
- Size (cm):** Height 15.5, length 29.5, width 23.7
- Weight:** 6kg.

Mk.IV (Example #2).

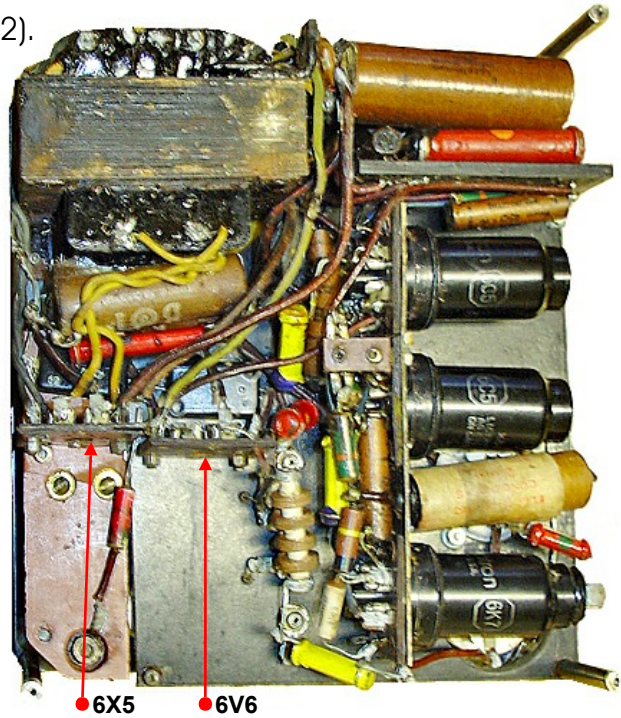
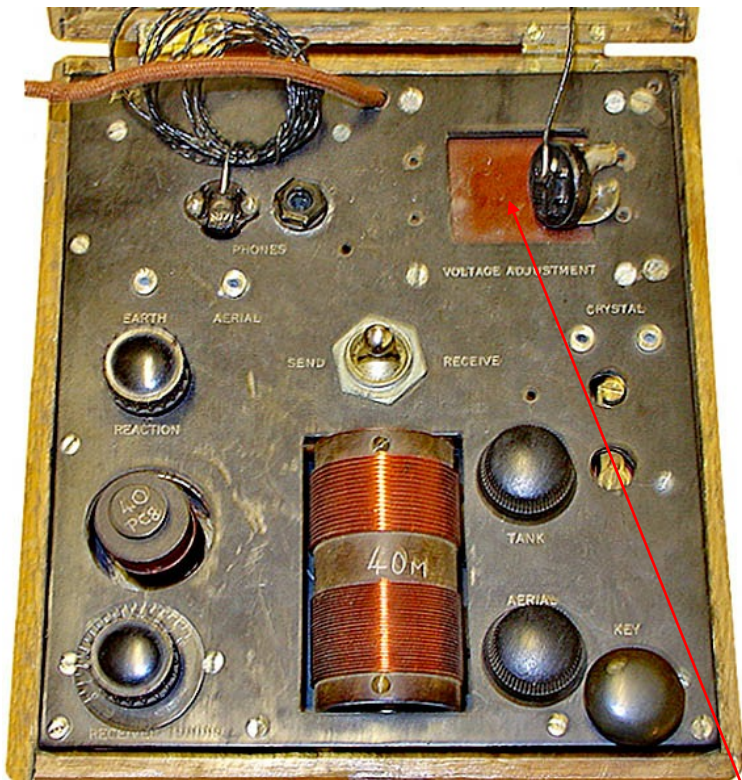

Detached from its enclosure, this internal view shows the construction of a Mk.IV, and the replacement mains transformer. The type 6X5 rectifier and type 6V6 transmitter valves were temporarily removed for taking this photo. The type 6K7 should be 6SK7.

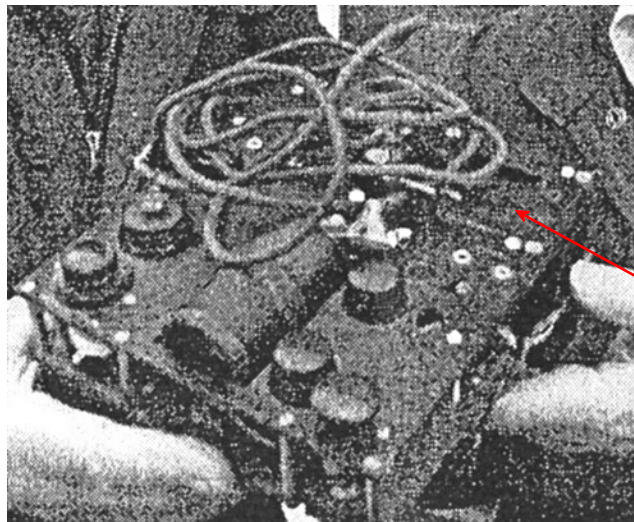

A b/w photograph from an unknown source shows the same Mk. IV, example #2.

On this page are photographs of a Mk.IV, example #2, which was dropped in Norway in January 1942. It is believed that the AC mains transformer was replaced and the voltage selector removed at a later stage. On the top left-hand side of the front panel, handwritten letters 'PC8' were visible, believed to indicate serial number 8; 'PC' could not be identified.

The receiver plug-in coil was also marked 'PC8', corresponding with the calibration table in the lid of the case. Two small bulbs with each a wire loop for tuning the transmitter to maximum brilliance were mounted inside the transmitter coil. According to the handwritten note on the table glued to the inside lid of the box, this receiver was calibrated on 7-10-1941.



AC mains transformer replaced and voltage selector removed.

Bulb with wire loop inside the coil.

Mk.IV (Example #3).

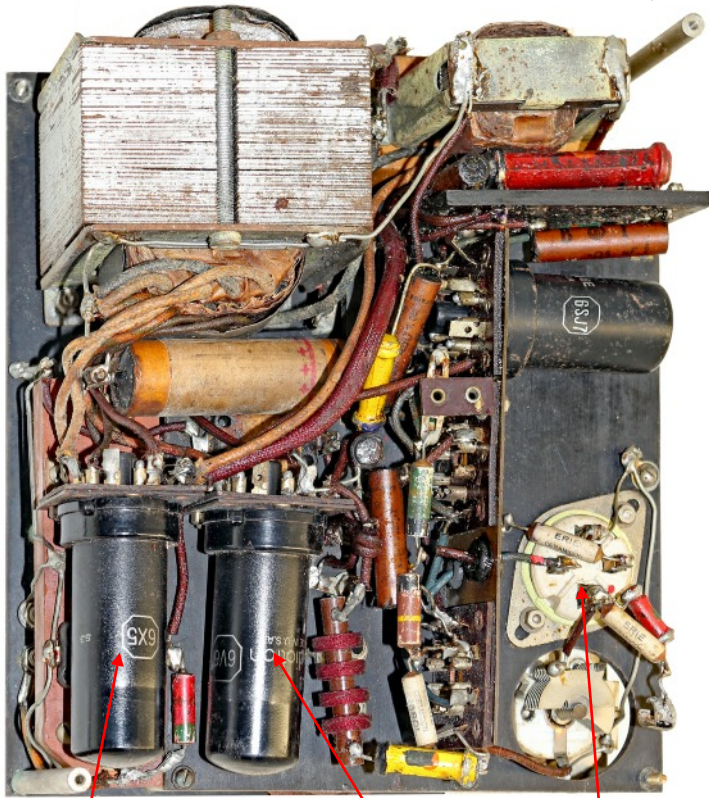

The 6X5 rectifier (left) and the 6V6 transmitter valve (right) were present. Two 6C5 valves were missing, and the 6SJ7 was inserted at a wrong position.

4-pt. Socket for receiver coil.

A rare opportunity and some observations.

Very shortly after finding the photo that initiated the thought that the Mk.VI and its variations 2 and 3 (as suggested in WftW Volume 4) might be a Mk.IV, Ronald Evers from Andelst, Holland, came to visit after a long-delayed appointment for taking photographs of a few items from his collection of agent's sets. He also brought with him a small oak wood box which surprisingly contained a Mk.IV with serial number PC 14, calibrated on 2nd August 1941 (see the photographs on this page labelled as example #3).

After taking photos of the front plate, the wooden case was removed, revealing the original AC mains transformer (which differed considerably from the replacement transformer as shown in example #2). Upon comparing the front plate photographs of all known examples, much to our surprise, we noticed a couple of extra unmarked sockets connected in parallel with the Morse key, allowing for the connection of an external Morse key.

The general construction of the Mk.IV was very compact but rather fragile: for example, using a flimsy tin sub-chassis for mounting the receiver valves. In addition, the wooden case would not withstand very heavy handling. Another serious problem might have been the heat developed by the mains transformer, rectifier, and other valves, for which the five holes in the wooden front were rather meagre for adequate air circulation. In addition, it could only be powered from AC mains which was not always available, which led to a long delay in the operation of the 'Arquebus' station.



Mk.IV front panel and enclosure with ventilation holes of example #3 had serial number PC 14. The receiver was calibrated on 02-08-1941.

Slot for guiding mains lead when not in use.

Detail view of the built-in Morse key. The spring tension and contact gap could be adjusted via two small holes in the front plate.

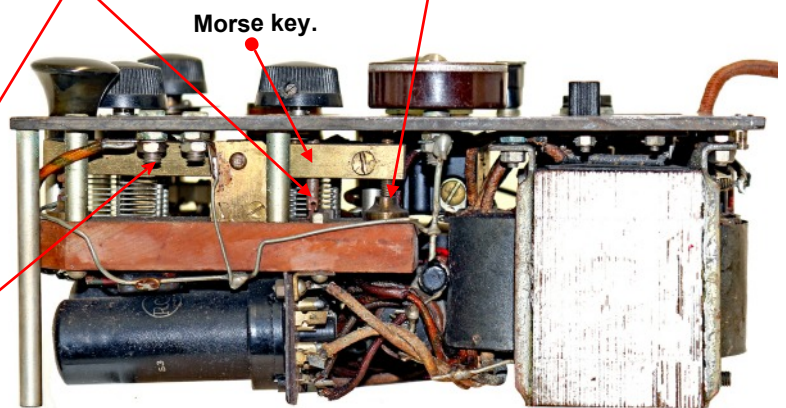

Morse key.

A side view of the chassis showed the Morse key, mains transformer and type 6X5 rectifier valve.

Sockets to connect an external Morse key. As there are no engravings on the front panel, this might be a later addition, although the sockets do look authentic and identical to those for connecting the crystal, aerial and earth.

Mk.IV (Example #4).

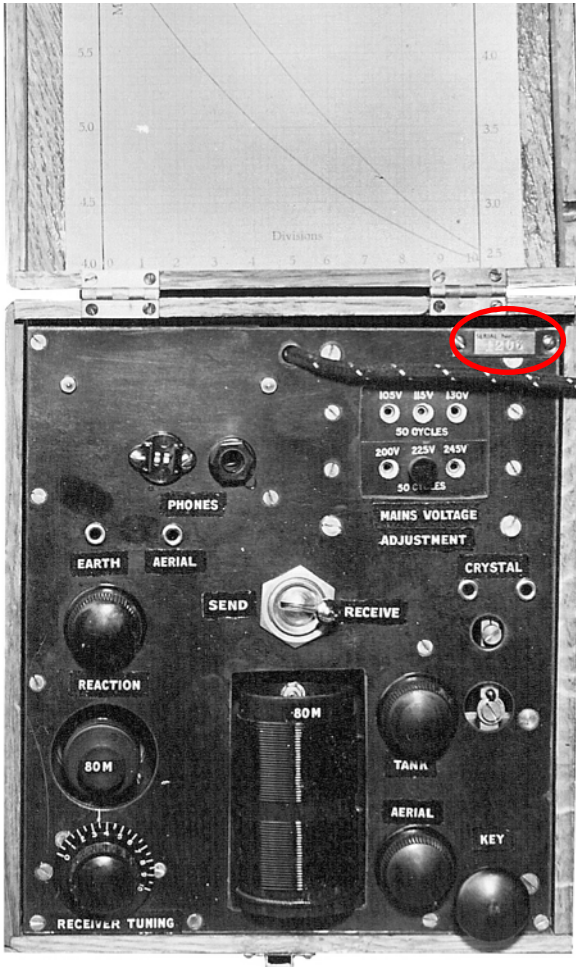

This Mk.IV (Example #4) was dropped in North Jutland, Denmark, on the night between 31 July and 1st August 1942. The serial number (top right-hand side) was 1206, calibrated on 8 April 1942 (More details on Page Mk.VI-5 of WftW Volume 4). Note the single wire loop at the bottom side of the tank coil connected to the tuning bulb inside the coil. It is believed to be a later variation when considering the fitting of a serial number plate (with s/n 1206) and the lettering by transfers.

Mk.IV (Example #5).

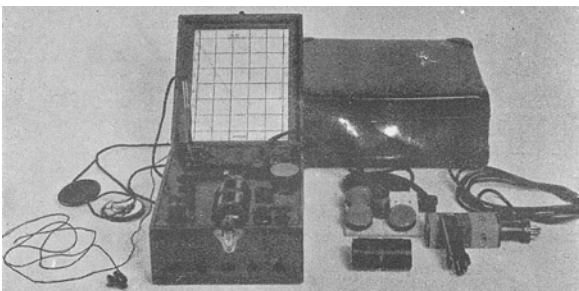

This photograph was retrieved from a WW2 German 'Ordnungspolizei' handbook, 'Die Funkpeilung der kurzen Wellen, Teil 1', which mentioned that this set was captured in 'Western Europe' in 1941. In this book, it was named 'A6', presumably taken from the calibration table sheet in the lid; this was possibly the serial number of the receiver tuning coil. In the technical description, the valve types of the receiver and transmitter were interchanged. However, the photograph provides evidence that these sets were issued in a small suitcase.

Mk.IV (Example #6).



Serial number plate.

Wire loop to tuning bulb inside the coil.

Shortly before closing this chapter, Reinhard from Germany advised to have a look at the website of the Canadian War Museum, where he had spotted photographs of a complete and very well-preserved suitcase set, which turned out to be another Mk.IV, with serial number 1111 (Allocated as example #6). It was identical to those seen in earlier photographs and the one Ronald had shown, with the exception of a serial number plate and without lettering on the controls. For that reason, one operator had added a pencil drawing of the functions of the controls on the calibration table at a later stage.



'Suitcase radio, CWM 20100109-010, Canadian War Museum'.

Mk.IV (Example #7).



Front panel view of a Mk.IV, on display at the Arquebus Krigs-historsk Museum after the restoration in 2024.

Arquebus

The Arquebus War History Museum was named after Sverre K. Andersen, who conducted illegal radio operations during World War II under the cover name 'Arquebus.' Although not specifically an SIS agent, Sverre was also affiliated with the Special Operations Executive. In 1941, Andersen arrived in Norway from Great Britain, disembarking at Bremnes. On the farm Eikås in Bjoa, where he posed as a farm hand, he established and operated a secret radio station. This station transmitted messages to Great Britain and held the distinction of being the longest continuous operation among the illegal radio stations in occupied Norway. It remained in operation until the German surrender.

The original radio transmitter he brought from England, an Mk.IV serial PC50 as shown on this page, was designed for alternating current, which did not exist at Bjoa. Additionally, the transmitter was damaged by seawater, rendering it unusable. After a prolonged period of uncertainty and waiting, they established contact with England via the 'Theta' transmitter in Bergen. Bjørne Holth-Larsen from Kongsvinger delivered a new radio known as 'Early Type 3' which is also on display at the museum, cycling over Haukelifjell with a 25-kilo suitcase.

A full account on Arquebus SIS agent Sverre K. Andersen can be read at: <https://www.erlingjensen.net/arquebus/>

Sverre's covert name came from 'arquebus', a form of long gun that appeared during the 15th century. The term arquebus was derived from the Dutch word haakbus ('hook gun'), applied to various forms of firearms from the 15th to 17th centuries. Originally, it referred to 'a hand-gun with a hook-like projection or lug on its under surface'.

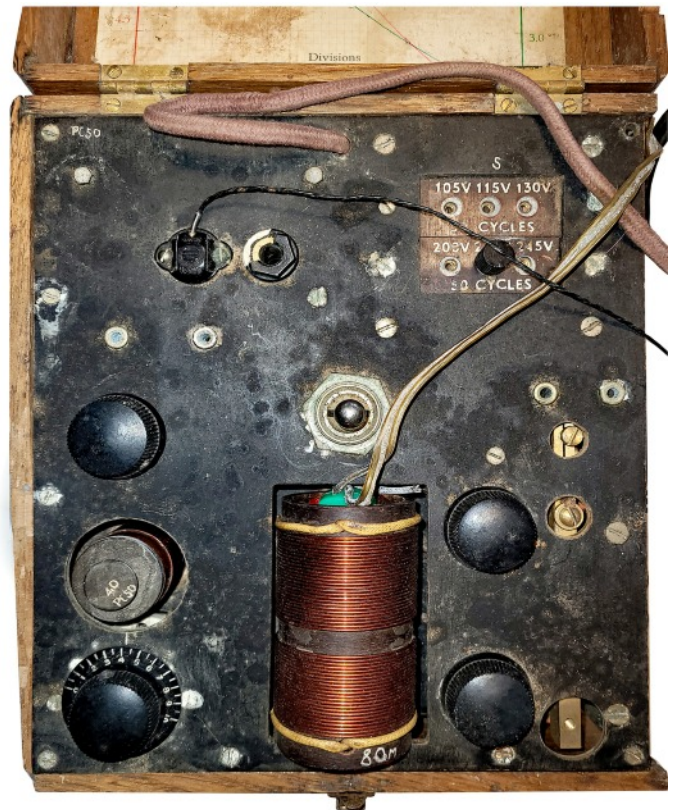

Mk.IV (example #7), serial PC 50, calibrated on 24-9-1941 (example #7), photo taken in 2022 before the restoration at the Stavanger Museum in 2024. There was no lettering on the controls, and the Morse key knob was missing.

Photographs on this page courtesy Paul Lande, IA6IN.

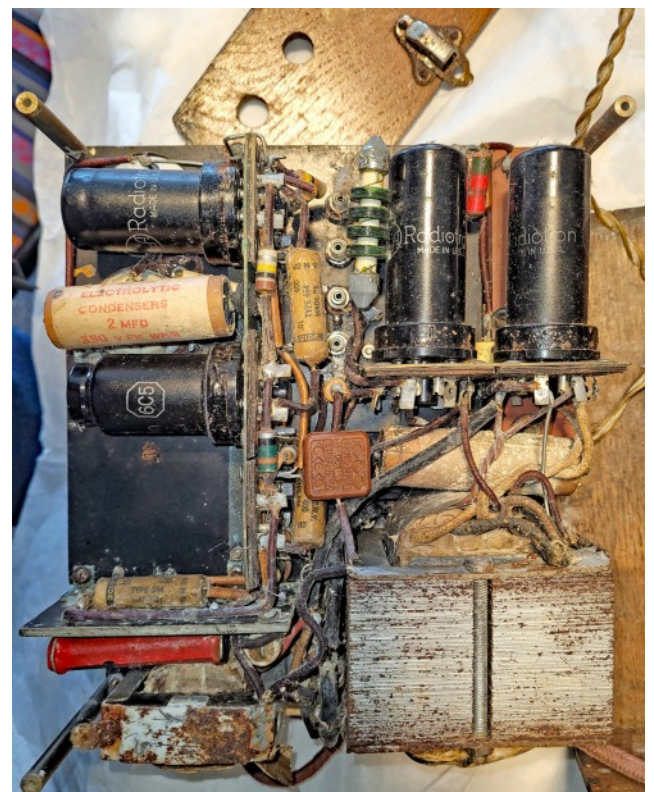

Mk.IV (example #7), view of internal components.

Mk.IV variation 2 (Example #8).

- DC power unit cover
- Reaction
- Phones plug
- Calibration card
- Plug-in receiver coil
- Aerial socket
- Receiver tuning dial
- Morse key

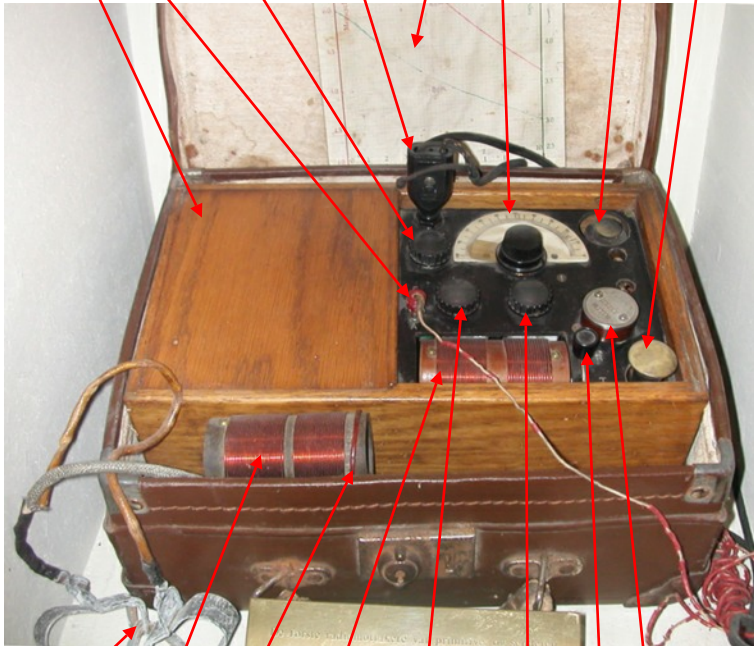

- Battery poles clamps
- 80M Tank coil
- Wire loop
- 40M Tank coil
- Aerial tuning
- Tank tuning
- Rec/transmit switch
- Crystal

Used from January 1942 until March 1944 in Kvinderdal, Vest-Agder, Norway, for communication with England was a Mk.IV variation provisionally named 'Mk.IV variation 2' (Example #8 above and below). The set is currently on display in the Norges Hjemmefrontmuseum (Norway's Resistance Museum) in Oslo. It was almost certainly powered by a 6V accumulator, considering the screened heavy leads and battery pole clamps in the foreground. This variation was smaller, with a different layout of controls, functionally similar and built as a single unit (without the usual internally fitted AC mains power unit). It was enclosed in an oak wood box, with a 6V vibrator power unit fitted on the left-hand side. There was not a hinged lid, but protection of controls was provided by the suitcase cover. The calibration sheet was attached at the inside cover of the suitcase. (Photographs courtesy Tom Høppe, DJ5RE).



Mk.IV variation 3 (Example #9).

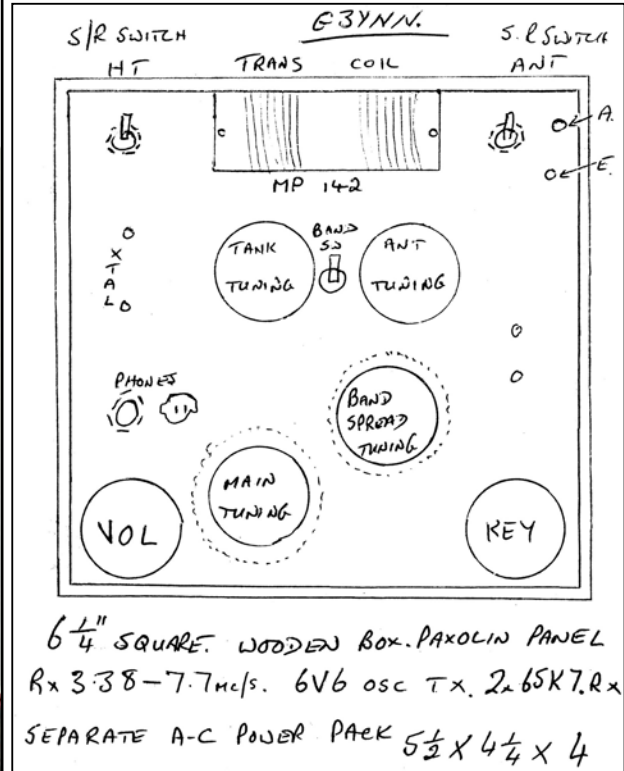

Drawing by G3YNN, believed to be a Mk.IV variation, here provisionally designated variation 3 (example #9).

Whilst browsing through old correspondence with Pat Hawker, a sketch drawn by G3YNN (not the present call holder) from an agent's set which was found in India. I vaguely remember that we could not identify this at the time and just assumed it was another variation of the Mk.VI.

With the current information, it can now be rather safely assumed that this was yet another variation of the Mk.IV, provisionally designated variation 3 (Example #9). Not to be confused with the (wrong) designation Mk.VI variation 3). This variation was a single unit, with a Paxolin front panel, enclosed in an oak wood box, using a separate AC power supply unit (and possibly a second power unit operating on DC). The layout of controls was different, although the Morse key retained its place in the bottom right corner.

Considering the band-switch, positioned between the tank and aerial tuning, it is believed that only one transmitter coil was required. There were no plug-in receiver coils. The 'band-spread tuning' knob might have been the friction drive coupled to the tuning dial, or a separate variable condenser of a small value. There was no single transmit/receive switch, but two toggle switches for HT and aerial. The number of valves in the receiver was reduced from three (6SK7 and two 6C6) to only two type 6SK7 valves. Geoffrey Pidgeon, author of 'The Secret Wireless War', mentioned that he had to destroy a number of SIS agent sets after the war whilst in India. This might have been one of this batch which was 'liberated' from this action.

Three variations and two minor differences.

A study of the front panels, calibration curve sheets, and general construction of the eight examples of the Mk.IV in this chapter led to the belief that (at least) three variations were produced: the first model designed in late 1940 or early 1941, and later variations developed in 1941 and issued in 1942. The very minor differences of the initial model were the addition of a serial number plate, replacing the handwritten serial number, and the absence of engraved lettering of controls, replaced by transfers (example #4) or no text at all in the 'Canadian' Mk.IV example #6, and station Arquebus (example #7).

Precursor of the Mk.VII 'Paraset'?

In light of the fact that the plug-in coils and mains power supply of a Mk.IV occupied considerable space, and a DC-powered variation would have been desirable (which was already realized to some extent in version 2 and particularly in variation 3), along with a rather fragile wooden case and possible heat development issues, it may be speculated that the Mk.IV eventually evolved into the Mk.VII, better known as the Paraset.

The Mk.VII retained the same technical and operational features but in a much smaller form factor. It was powered from AC mains or 6V DC using two different power supply units. There was hardly any risk of overheating due to a separate power unit and externally placed valves.

The initial Paraset, enclosed in an oak wood box, was later replaced by a version housed in a much stronger steel box, retaining the same dimensions. This version had a 3-point power socket replacing one of the two headphone sockets, and silk-screen lettering was applied to the front panel.

External Morse keys.

It is interesting to mention a regularly observed local modification of either Mk.IV or Mk.VII where an operator preferred to connect his own Morse key. Considering the construction of the internal Morse keys, this would be less of a requirement for the key fitted in the Mk.IV, which was of a much higher standard than that used in the Mk.VII. The key fitted in the second version of the Mk.VII featured a slightly improved construction. In the early Mk.VII, this modification simply involved drilling a hole in the wooden case, while in the later metal box version, two holes were usually drilled in the metal front plate for fitting two banana-type sockets.

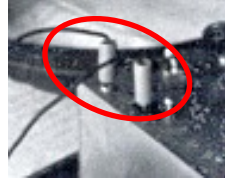

Two examples of the fitting of sockets for connecting an external Morse key.

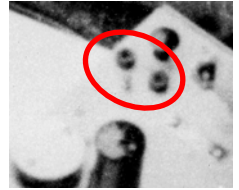

Initial version of the Mk.VII Paraset, enclosed in an oak wood box.

Two different styles of headphone sockets, as in Mk.IV.

Three position receive-off-transmit switch, as in Mk.IV.

Tuning bulbs. In Mk.IV fitted in the plug-in TX coil.

The power cable entered through a hole in the right-hand side of the box

Two 6SK7 valves as in the later Mk.IV variations.

Tuning dial with fine tuning control.



To use an external Morse key, operators drilled a second hole in the box to pass a cable connected in parallel with the original key.

Photographs collection Ronald Evers.

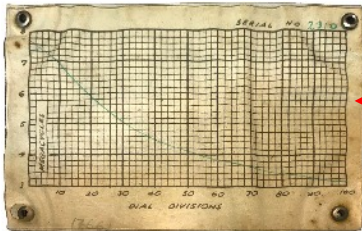

Silk-printed drawings, protected by a celluloid cover, with explanations of the functions of controls and receiver frequency calibration graphs, were issued with the early version of the Mk.VII as an aid in the absence of printed lettering.

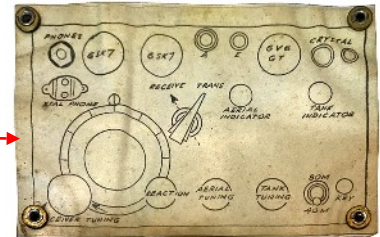

Later issued steel case version of the Mk.VII.



An early version Mk.VII and AC power supply unit fitted in an original suitcase, used by Oluv Reed Olsen (right).

The AC power unit shown here was an early version fitted in a wooden box.

A two-conductor cable connected in parallel with the Morse key, terminating in two flying sockets for connecting an external Morse key.

A four-point plug and cable connected to the power supply unit.



Mk.VII 6V DC power supply unit.



Mk.VII AC mains power supply unit.

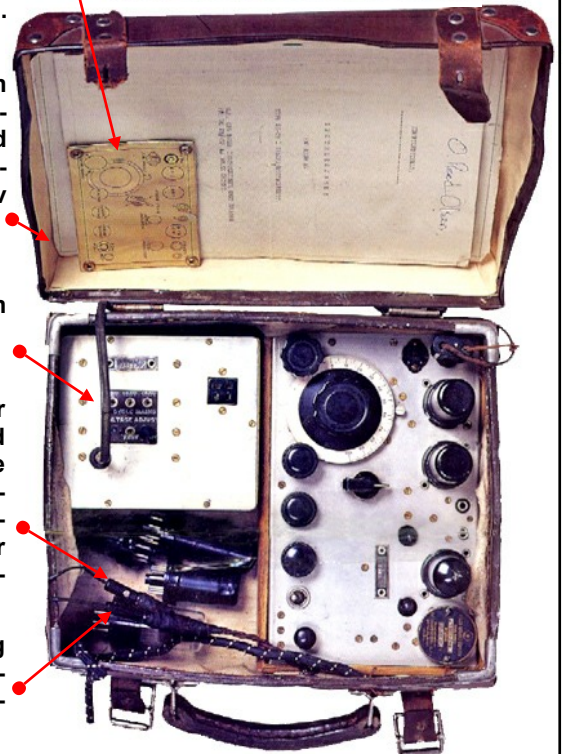

Building a Mk.IV replica.

Mk.IV replica built by Peter Sables, G4MRU.

Reading 'The Paraset Radio' book by Hiroki Kato, one may learn about the numerous replicas that were (and still are) made of the Mk.VII Paraset, and the challenges involved in crafting the metalwork. It might be advantageous to consider creating a replica of the Mk.IV, where an oak wood case plus Paxolin front are much easier to construct. There is a choice of three variations to build, and a Mk.IV is functionally similar to a Mk.VII Paraset. The Mk.IV variations

2 and 3 might be particularly interesting to build since they used a separate power supply unit, simplifying the choice of an AC mains transformer.

When closing this chapter and in the nick of time, Tom Höppe, DJ5RE, who was sent a draft copy of this supplement, returned with photos of two variations of a Mk.IV constructed by the late Peter Sables, G4MRU, in 2012.



Inspection of a Mk.IV replica: The builder Peter Sables, G4MRU (left), John Pether, G4JGG (centre), and Tom Höppe, DJ5RE (right).

Photograph courtesy Bernhard, DL5RDP.



A functional replica of the Mk.IV was made by Peter Sables. It should be noted that both replicas were marked as Mk.VI, as suggested at the time of building in WftW Volume 4.



A functional replica of the Mk.IV version 2 by Peter Sables.

Mk.IV replica built in 2020 by Paul Lande, LA8IN.

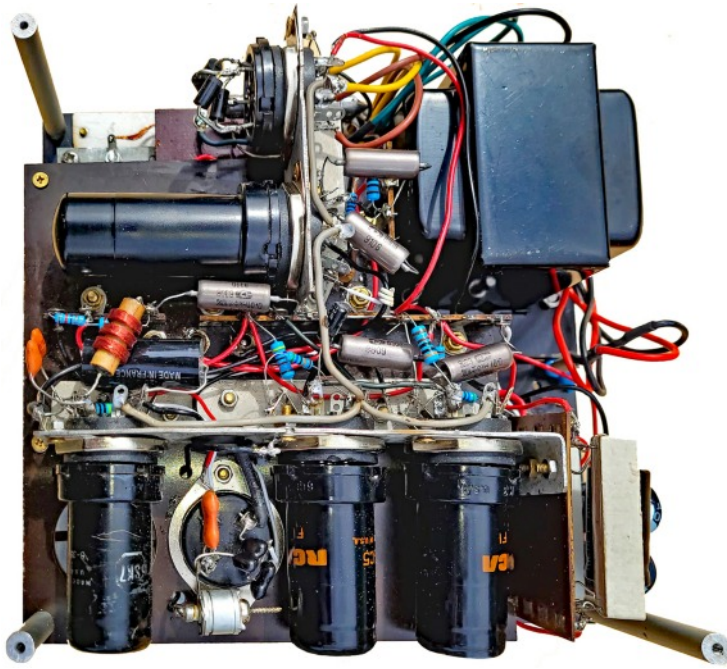

View of components in the Mk.IV replica built by Paul Lande. Notice the homemade bridge rectifier built on an old valve base, inserted into the socket of the original 6X5 valve.



View of the front panel of Paul Lande's Mk.IV replica.

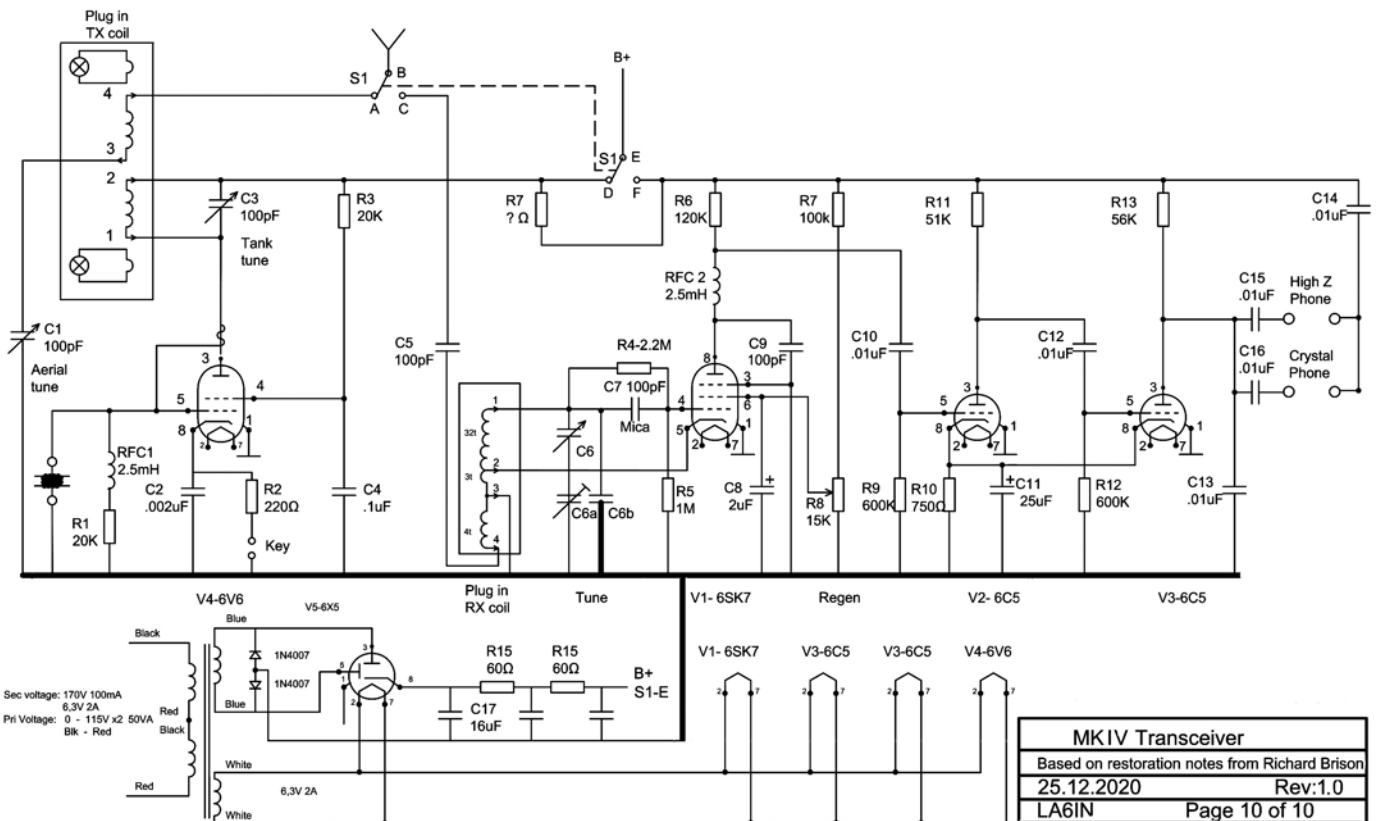

The Mk.IV circuit diagram, based on restoration notes by Richard Bison in Canada and drawn by Paul Lande (LA6IN), was used for building his replica Mk.IV. In the AC mains power supply section of this circuit diagram, Paul opted for a bridge silicon rectifier since no suitable transformer could be found. Interestingly, R7, located at points D and F of S1, was initially thought to be used for tuning to the transmitter frequency but was eventually abandoned as impractical. Additionally, capacitors C6b and C6d were carefully selected to ensure full coverage of the 80m amateur radio band. Compare this circuit with that of the Mk.VII Paraset on the next page.

Circuit diagram of SIS Mk.VII (Paraset).

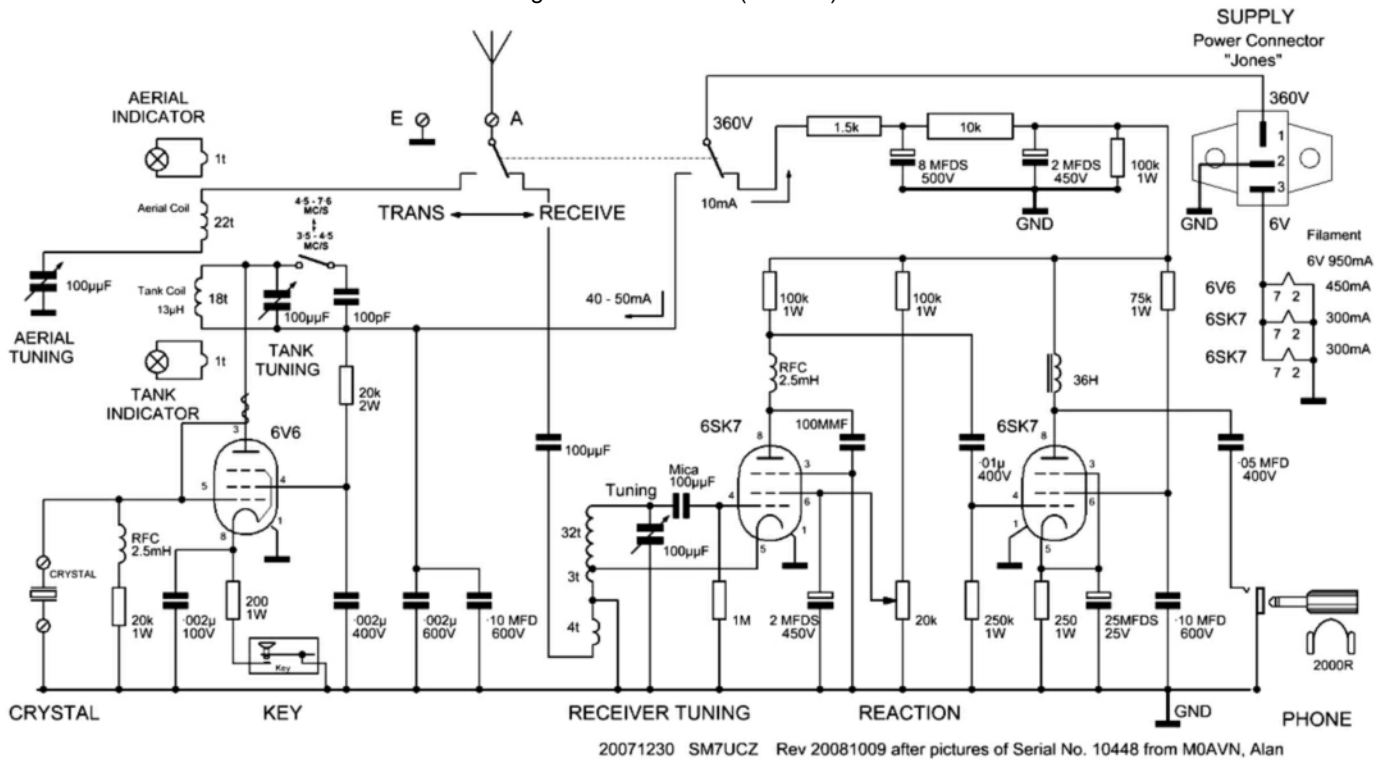

A suggested Morse key for a Mk.IV replica.

Upon observation of the Morse key knob in the Mk.IV replica constructed by Peter Sables on page 8, it appeared to be a Key W.T. 8A No. 2 Mk.II (Design 2, variation A). Because the base of this readily available key is too wide for fitting in a Mk.IV replica, it can be adapted by carefully removing small parts from the sides. Additionally, it might be necessary to extend the height of the key knob with a few washers.

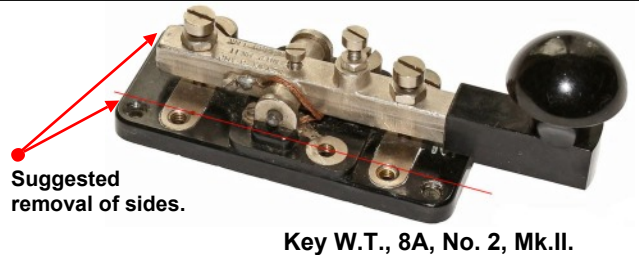

Epilogue

Looking back at the time when this chapter was started with only 2 pages, the discovery of a lost photo initiated the possibility that the earlier assumption in WftW Volume 4 of the SIS Mk.VI variations 2 and 3 was incorrect, and they might have actually been a (yet not confirmed) Mk.IV. Over just a couple of months, more photos of alleged Mk.IV suitcase sets were located. An actual example owned by Ronald Evers could be inspected. Even functional replicas had been constructed as early as 2012 in England and in Norway, both from photos published in WftW Volume 4.

This information eventually led to the (also not yet confirmed) conclusion that the Mk.IV and later variations were the forerunner of the Mk.VII, also known as the Paraset. The Mk.VII was functionally similar but more compact, not requiring cumbersome plug-in coils, less susceptible to heat generated by the internally fitted valves, and, most importantly, it could be operated from AC mains or a 6V accumulator using two separate power supply units.

References:

- Wireless for the Warrior, Volume 4, Clandestine Radio, Louis Meulstee et al., Dorset, 2004, isbn 0952063360.
- Correspondence with Pat Hawker, G3VA, 1999-2004.
- Correspondence with in Oluv Reed Olsen in 1999.
- Die Funkpeilung der kurzen Wellen im Nahfeld, Hauptamt Ordnungspolizei, Berlin 1943.
- Photographs and information of Mk.IV suitcase sets dropped in Norway courtesy Erling Langemyr, Norway.
- The Paraset Radio, Hiroki Kato, AH6CY, 2020, RSGB, isbn 9 781910 193952.
- Correspondence with Geoffrey Pidgeon around 2001.
- Key and plug assemblies, free to download Pamphlet No. 5 at <http://www.wftw.nl/downloads.html>
- Permission for publication of the Mk.VII Paraset circuit diagram kindly granted by Johnny Appell, SM7UCZ, retrieved from his most interesting website <https://sm7ucz.se>

Acknowledgements:

- With thanks to Ronald Evers of Andelst, Holland, for granting permission to inspect the internals and take photographs of his Mk.IV (Example #3) and early version Mk.VII Paraset.
- Photos taken of an Mk.IV (Example #6) from the collection of the Canadian War Museum in Ottawa were reproduced with kind permission at www.warmuseum.ca/collections/artifact/2210219.
- Oluv Reed Olsen granted permission for the use of a few selected photographs in 2000.
- I am grateful to Tom Höppe, DJ5RE, for his assistance in directing me to existing replicas of the Mk.IV, built by the late G4MRU, and for providing photographs of two variations.
- Many thanks to Paul Lande, LA6IN, for granting permission to publish a copy of his Mk.IV circuit diagram. Paul also provided comprehensive information and photographs of the 'Arquebus' Mk.IV.
- Pascal Drouvin, F8JZR, from France, kindly permitted to publish photographs taken from his rare SIS Mk.IV, variation 4.

Appendix 1. Mk.IV variation 4.

I must express that I was utterly amazed when Ronald Evers acknowledged the existence of a fourth variation of the Mk.IV agents transmitter-receiver, owned by Pascal Drouvin, from France. This set came from an OSS agent which used it in South-East France. Photographs of this Mk.IV were incorporated as an appendix to the original WftW Supplement Chapter 343 as version 1.01. Although the components and general construction of variation 4 was similar, it had a slightly different layout of the front panel. It is believed that in this variation more space was required for the mains power supply at the top end as the phones and aerial/earth sockets have been repositioned. In addition, the transmitter tank coil was placed horizontally to shift down the transmit-off-receive switch. It is unfortunate that the original Morse key was missing, and a temporary key had been fitted. If someone has this key (for a more detailed view, see page 3, bottom right) for sale or trade, please contact Pascal at f8jzr@wanado.fr

Mk.IV Variation 4 (Example #10).

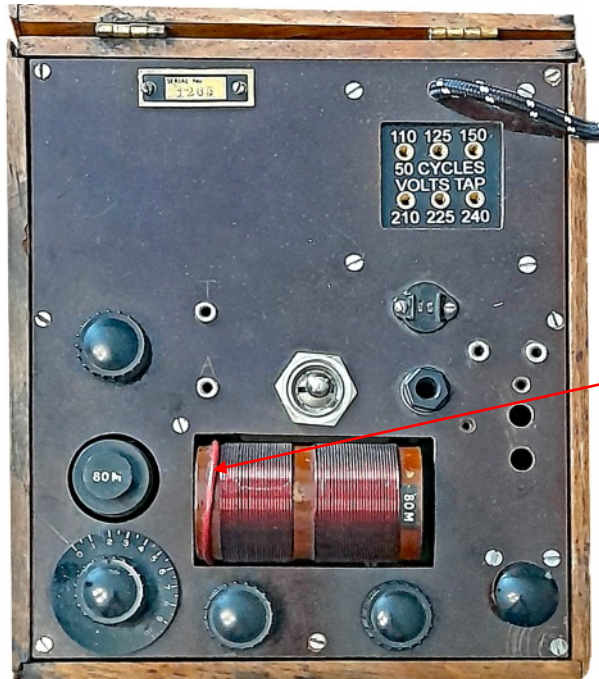

This is the front panel of the 4th variation of the SIS Mk.IV having serial number 1205. Fitted with a serial number plate, without lettering on the controls, and text transfers in place of handwritten lettering on the coils, suggest that this variation was a later build.

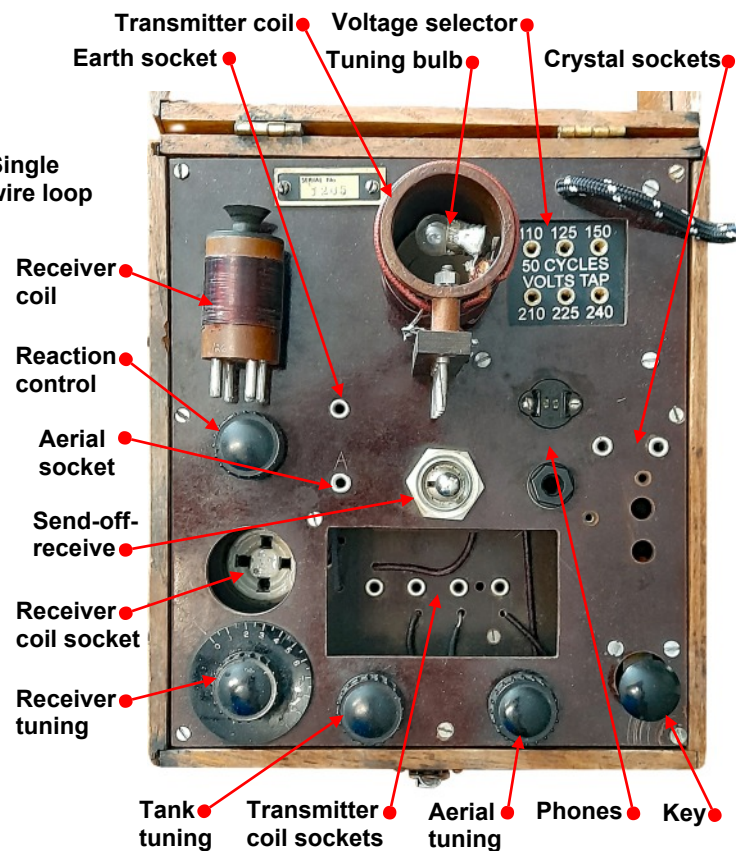

This photograph shows the sockets and associated 80M receiver coil (left), and 80M transmitter tank coil (right). Clearly visible inside the latter coil is a tuning bulb connected to a separate single wire loop on the outside of the coil.



Five ventilation holes were included in the front side of the oak enclosure, which was rather flimsy, but still strong enough considering the examples that survived.